

## V2 Dialler Programming Guide

### Installing your V2 Dialler

- Remove the telephone cable from the BT/Cable wall socket and insert the plug of the V2 Dialler.
- Plug your telephone lead into one of the 2 sockets on the side of V2 Dialler, the other spare socket on the V2 dialler is for you to add an extension phone, if required.

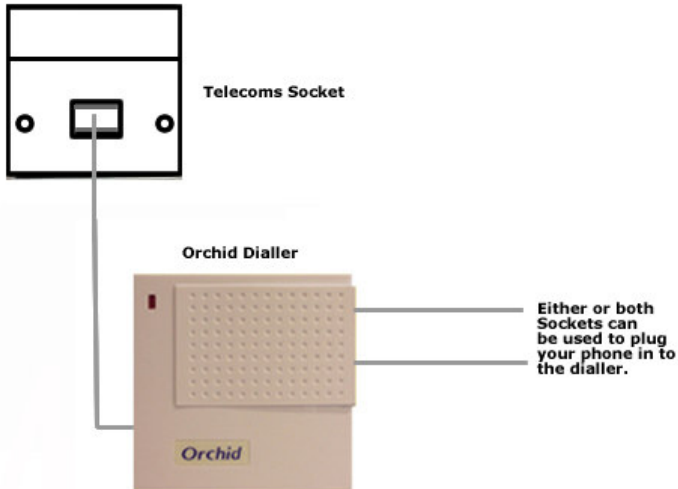

### With ADSL Broadband

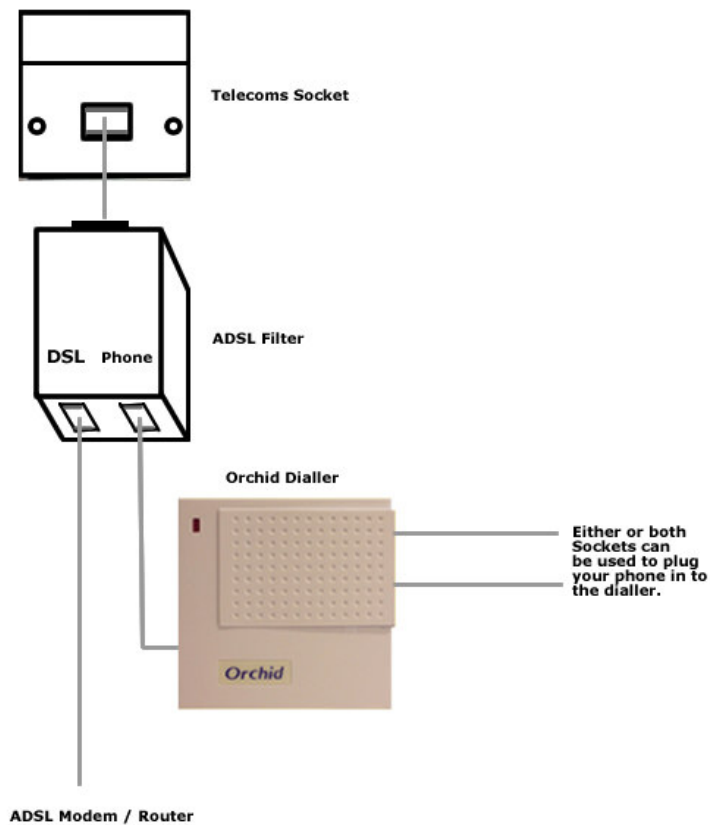

If you have an ADSL Broadband Filter, please ensure your filter is plugged directly into the phone socket with the dialler plugged into the 'Phone' side of the filter.

## Programming your V2 Dialler

When programming your Dialler please ensure that your phone is switched to Tone mode.  
You are now ready to program the Access Code of your chosen low cost call provider and your local area code.

### **To Programme your Local area code**

If you do not programme in your local area code, local calls will **not** go over your chosen low cost call provider.

- Lift the handset, the LED on the V2 Dialler will come on
- Dial \* \* \* **Area Code** \* 4
- Replace the handset

### **To Programme your carrier code for local & national calls (up to max 16 digits)**

- Lift the handset, the small red LED on the V2 Dialler will come on. (Dimly)
- Dial \* \* # **0 0 0** \* **1 8 8 6 6** \* 5
- Replace the handset.

### **To Programme your carrier code for International calls (up to max 16 digits)**

- Lift the handset, the small red LED on the V2 Dialler will come on. (Dimly)
- Dial \* \* # **0 0 0** \* **International Carrier Code** \* 6
- Replace the handset.

### **To exclude certain calls from going over your chosen low cost call provider**

Some calls such as 0870 or 0845 numbers may be more expensive over your low cost call provider, to prevent these calls being dialled you can program the dialler to exclude them as follows:

- Lift the handset, the LED on the V2 will come on
- Dial # \* \* 0870 \* 01
- Replace handset
- Lift the handset
- Press Redial and listen for all the digits to dial through
- Replace the handset

Up to 23 numbers can be excluded. To exclude other numbers repeat the above sequence replacing 0870 with the number you want to exclude and replace the last two digits with the next in sequence ie 02 up to 23. It is a good idea to keep a note of the numbers and their location (01 to 23) in case you want to change it in the future. To remove an exclusion entry with a location of 01 for example - dial: # \* \* \* 01

## Cable Customers

If your phone line is provided by a Cable company access to your low cost call provider is normally via a longer 0808 number and you'll also need to programme in a 5 second pause after the Access Code. This is done by inserting # five times after the Access Code, Call18866 for example will be 0 8 0 8 1 7 0 7 7 8 8 # # # # #.

NB. The correct access code can be found on the different Call Providers Web sites such as [www.call18185.com](http://www.call18185.com) or [www.call1899.com](http://www.call1899.com)

## Entering Programming Codes in to a Dialler

When "forcing home" or entering codes in to a dialler you can do it either one of two ways depending on what type of phone you have:

1. For **DECT (digital cordless)** phones you can dial in the code while the phone is On Hook (no dial tone) then Press the Dial key, put the phone to your ear and as soon as the last digit (beep) has been dialled hang up the call.
2. For **Corded** phones, enter the programming code or dial the "force home" code, ignore any BT announcement saying "the number you have dialled has not been recognised" then hang up lift up and press Redial. Again, listen for the digits to be dialled, then hang up when the phone has finished dialling the number.

Once you have finished entering your programming, make a test call to see if the dialler has picked you new routing. When using many of the Low Cost Call providers you should hear confirmation of the call cost, or check your online billing to see if the test call has been logged.

### **General Notes**

**Override** If you wish to override the Dialler at any time simply dial ## before the call, this is particularly useful if your cheaper call providers' network is temporarily unavailable or access to a particular number is prevented.

**General Services** Your telephone land-line is supplied by either BT or a Cable Company (e.g. Telewest, NTL). If you use any of their services such as the Speaking Clock or Directory Enquiries you will be billed by them.

### **141/1470 Services**

If you use 141 to withhold your number, you must dial the Access Code (e.g. 18866) as well after 141, and then the number. If you want to permanently withhold your number on every call you should programme 141 in front of the Access Code.

Example: If your chosen low cost call carrier is 18866, the programming sequence is as follows:

- Lift the handset, the LED on the V2 Dialler will come on
- Dial \* \* # 0 0 0 \* 1 4 1 1 8 8 6 6 \* 5
- Replace the handset
- Lift the handset
- Press the Redial Button and listen for all the digits to dial through
- Replace the handset

### **BT Ringback**

If you use the 1471 service do not press 3 when prompted to return the call, as this will be billed by BT. Simply cancel the call and dial the number in the normal way, it will then go over your low cost call provider as programmed in the Dialler.

### **Call Barring & Time of Day Functionality**

If you require more complex programming such as time of day routing, Call Barring and Number Translation features you will need a V4 or V4+ Dialler.

### **General Information**

If you have any queries please contact us on 01572 717888 or Email [support@orchid-electronics.com](mailto:support@orchid-electronics.com)

To see our full range of products on line, simply visit our web site at [www.orchid-electronics.com](http://www.orchid-electronics.com)